

MP0205

INSTALLATION INSTRUCTIONS

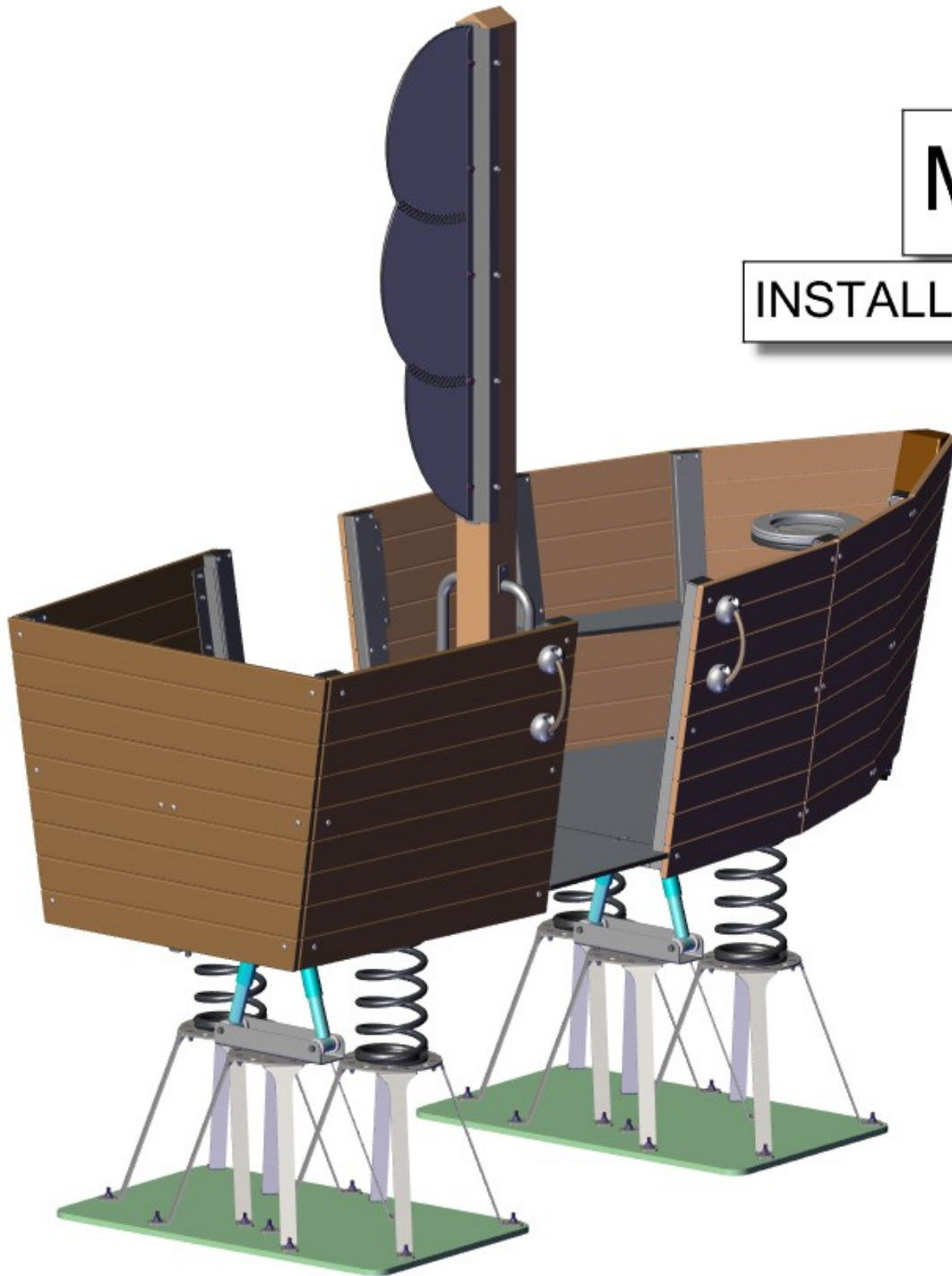

# Excavation guide

For Safety Sand

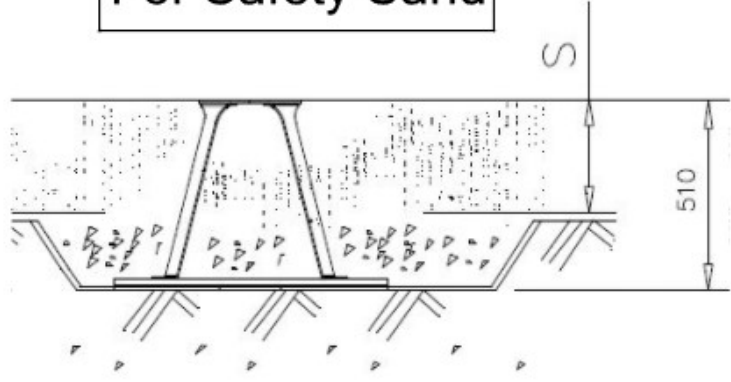

For Bark

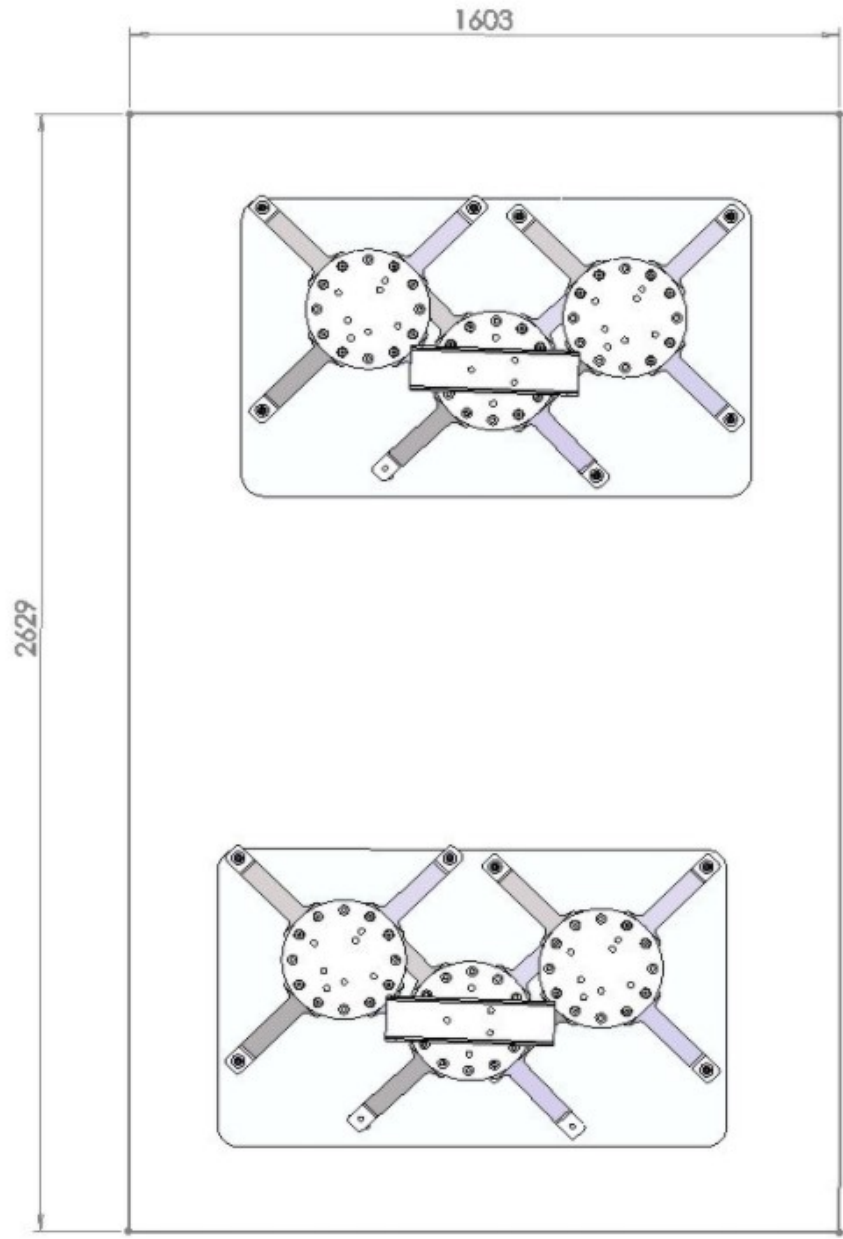
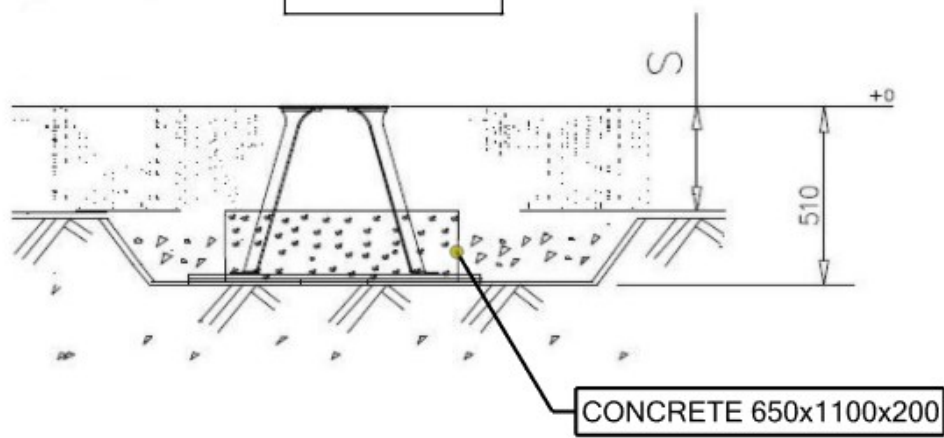

EN/AS Impact Area 20,7 m<sup>2</sup>

Falling Space 20,7 m<sup>2</sup>

Max Falling Height 1000mm

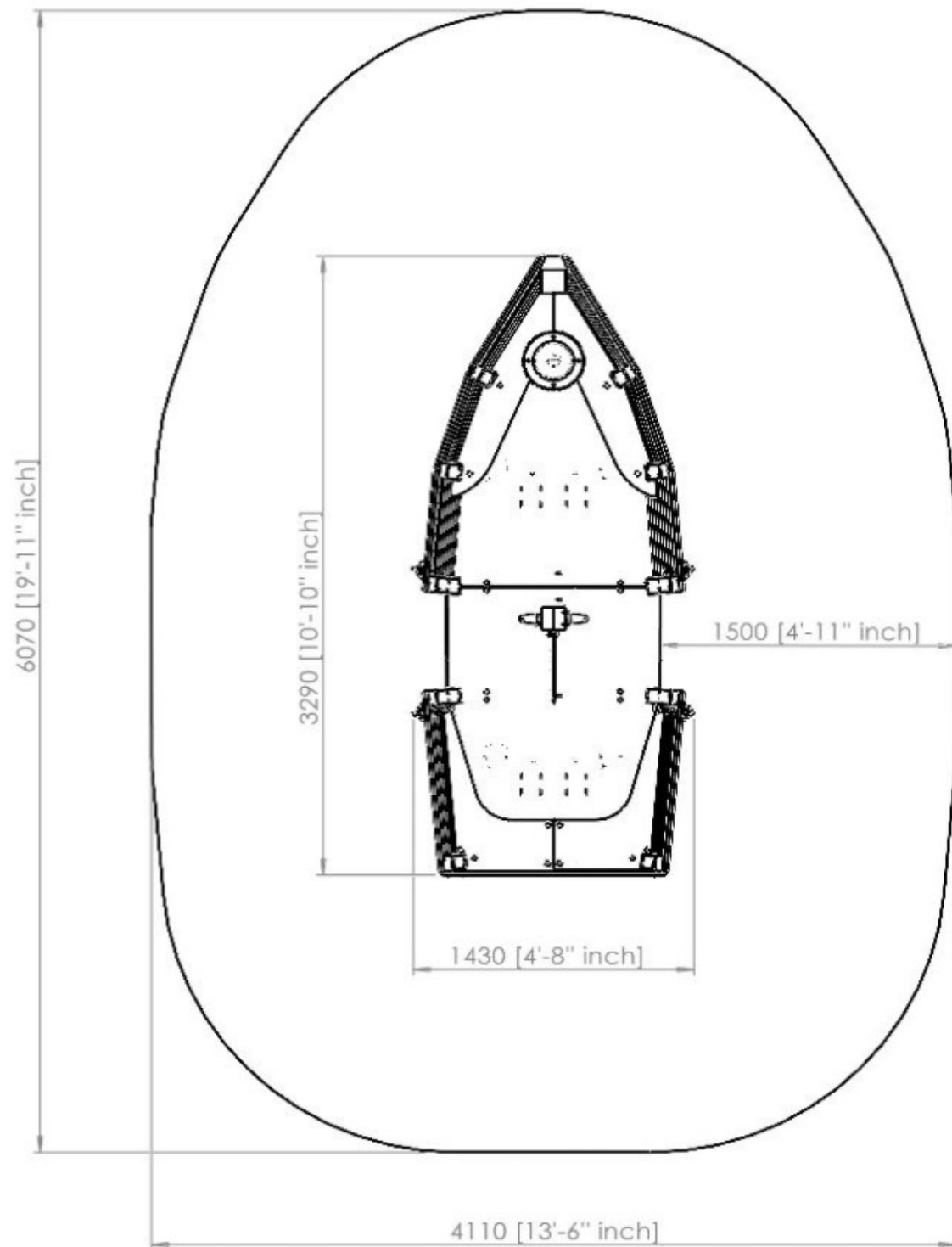

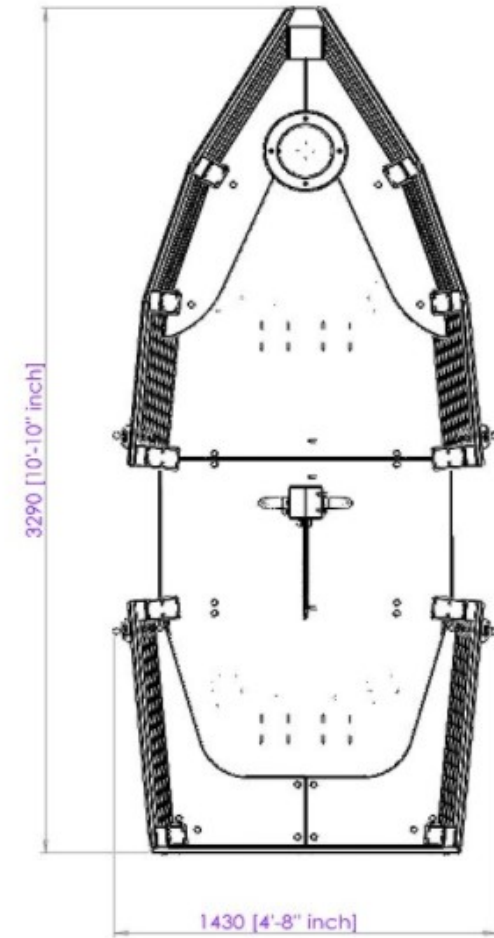
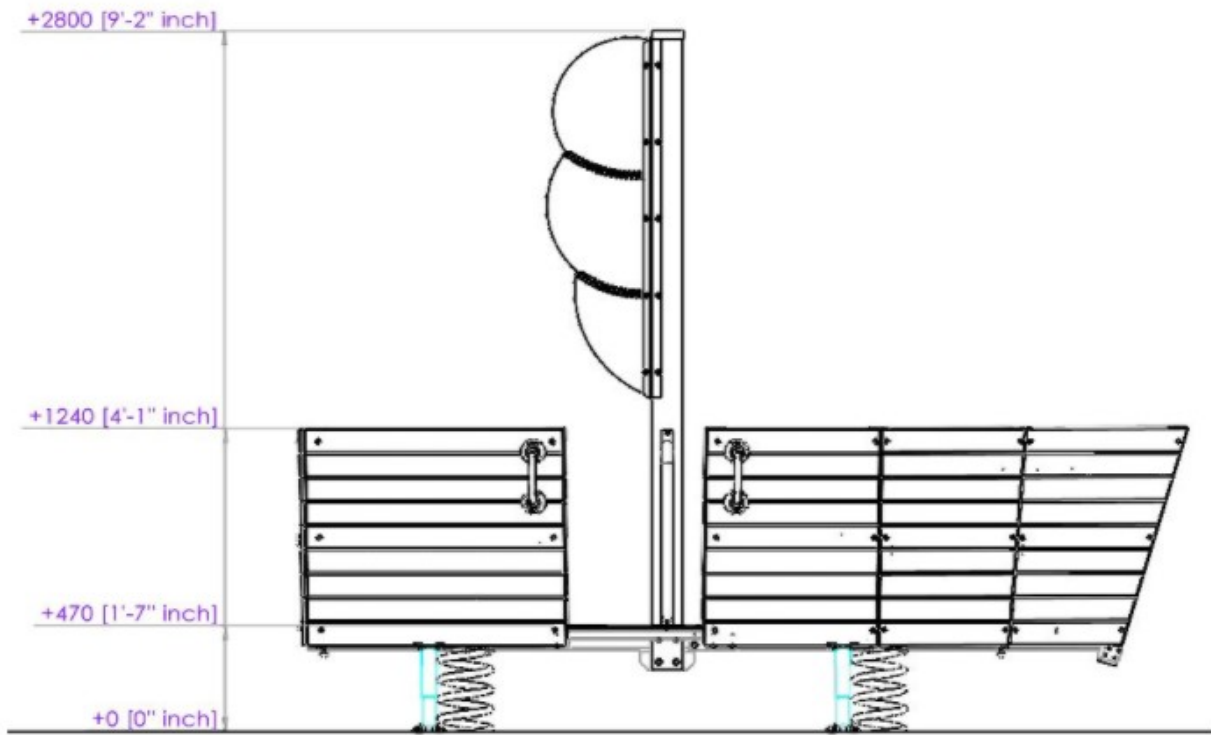

900965 (x8)

909638 (x16)

904917 (x8)

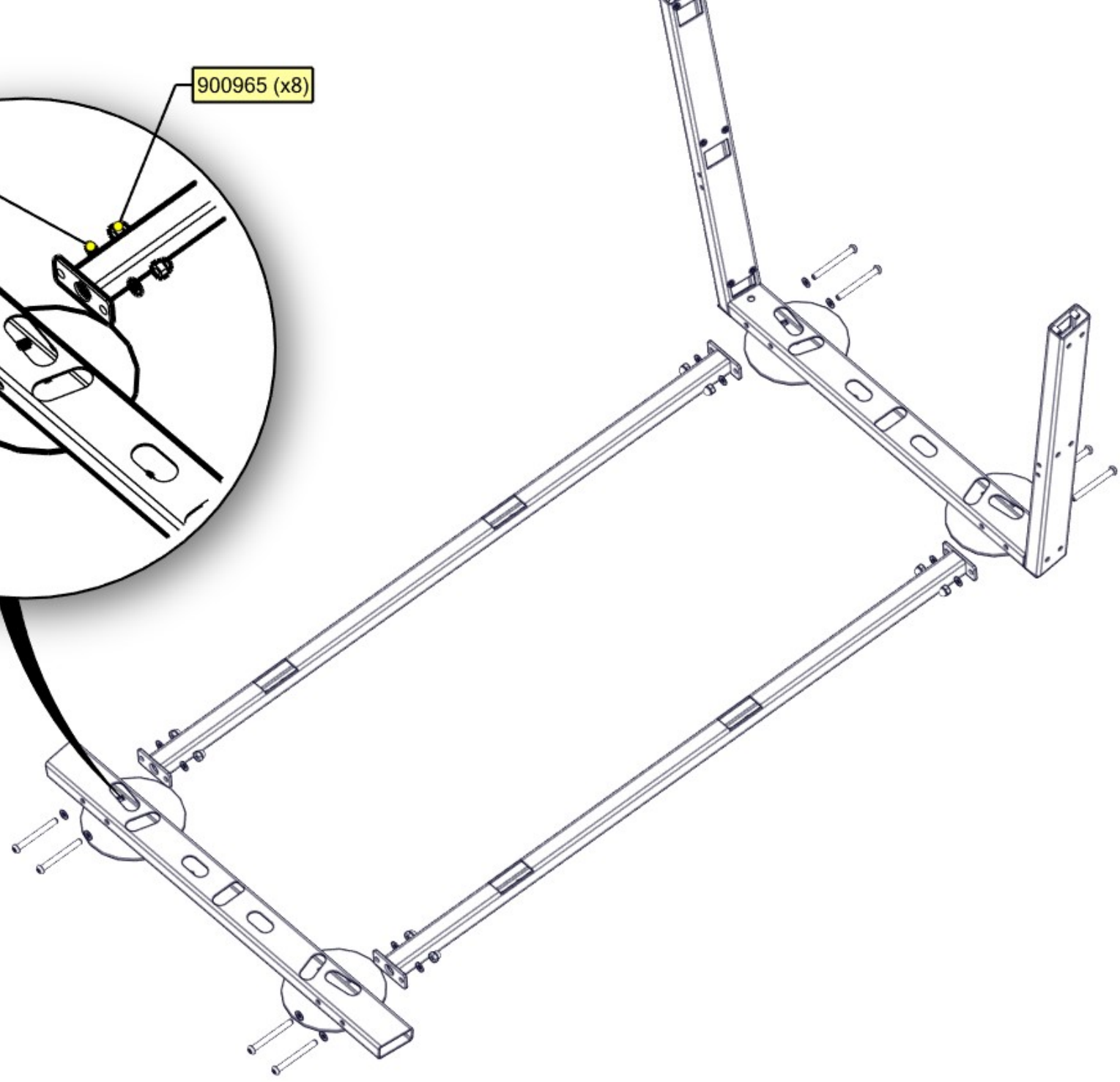
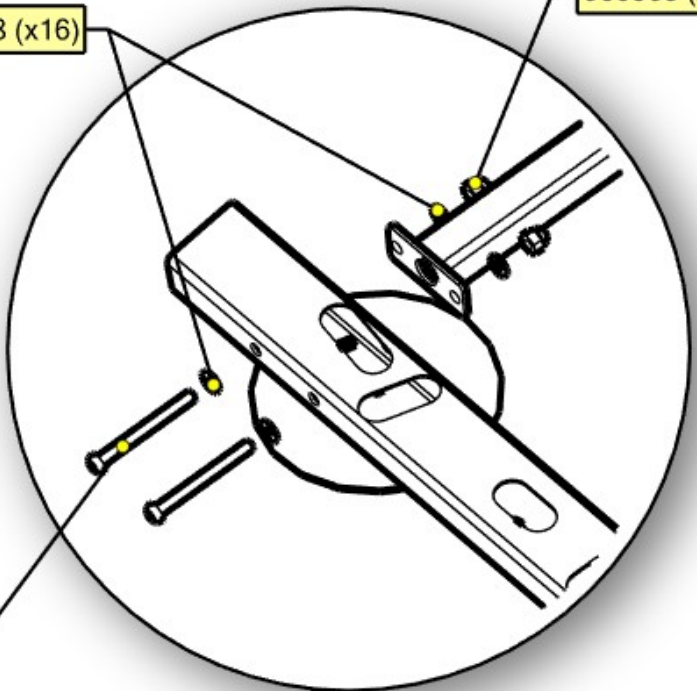

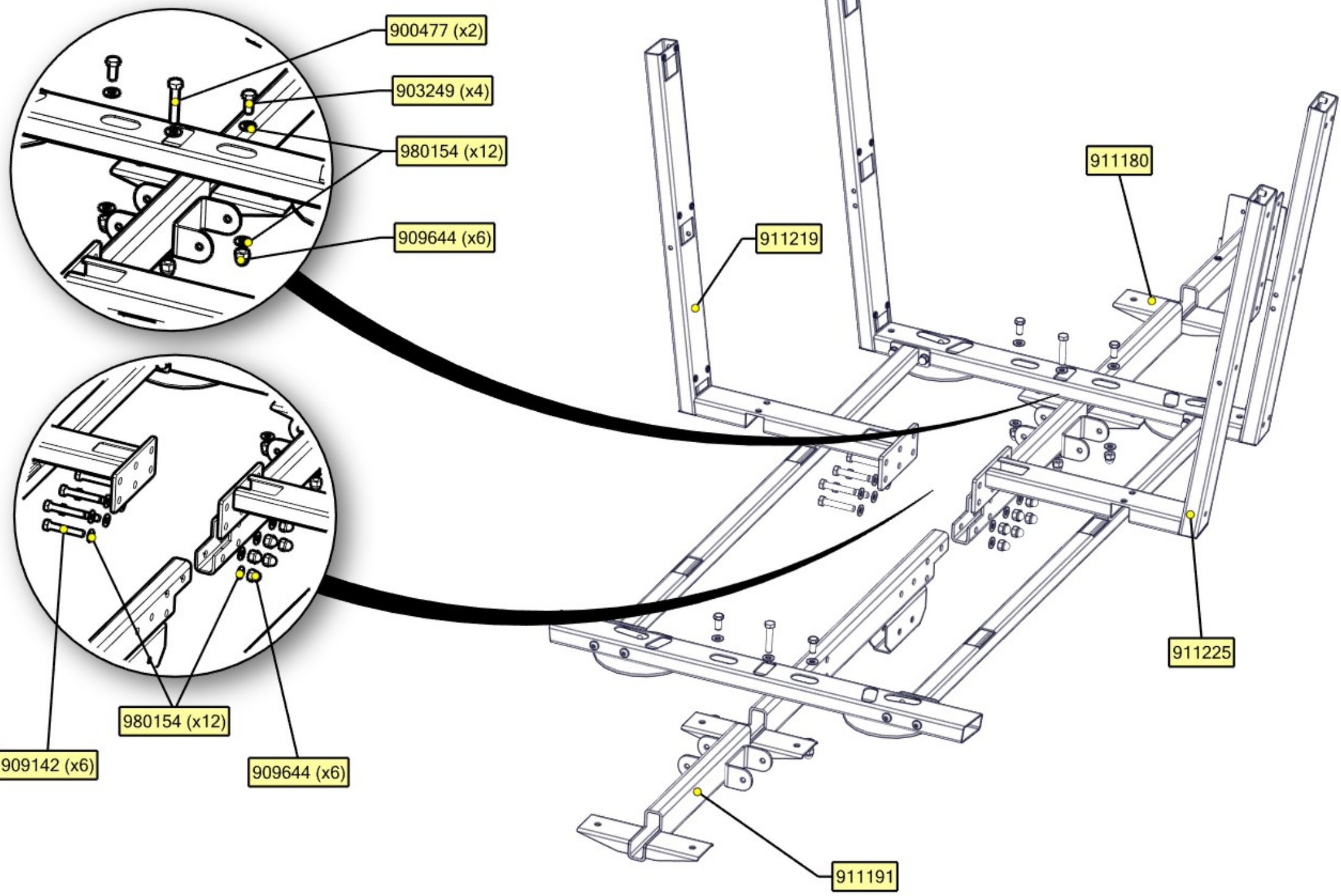

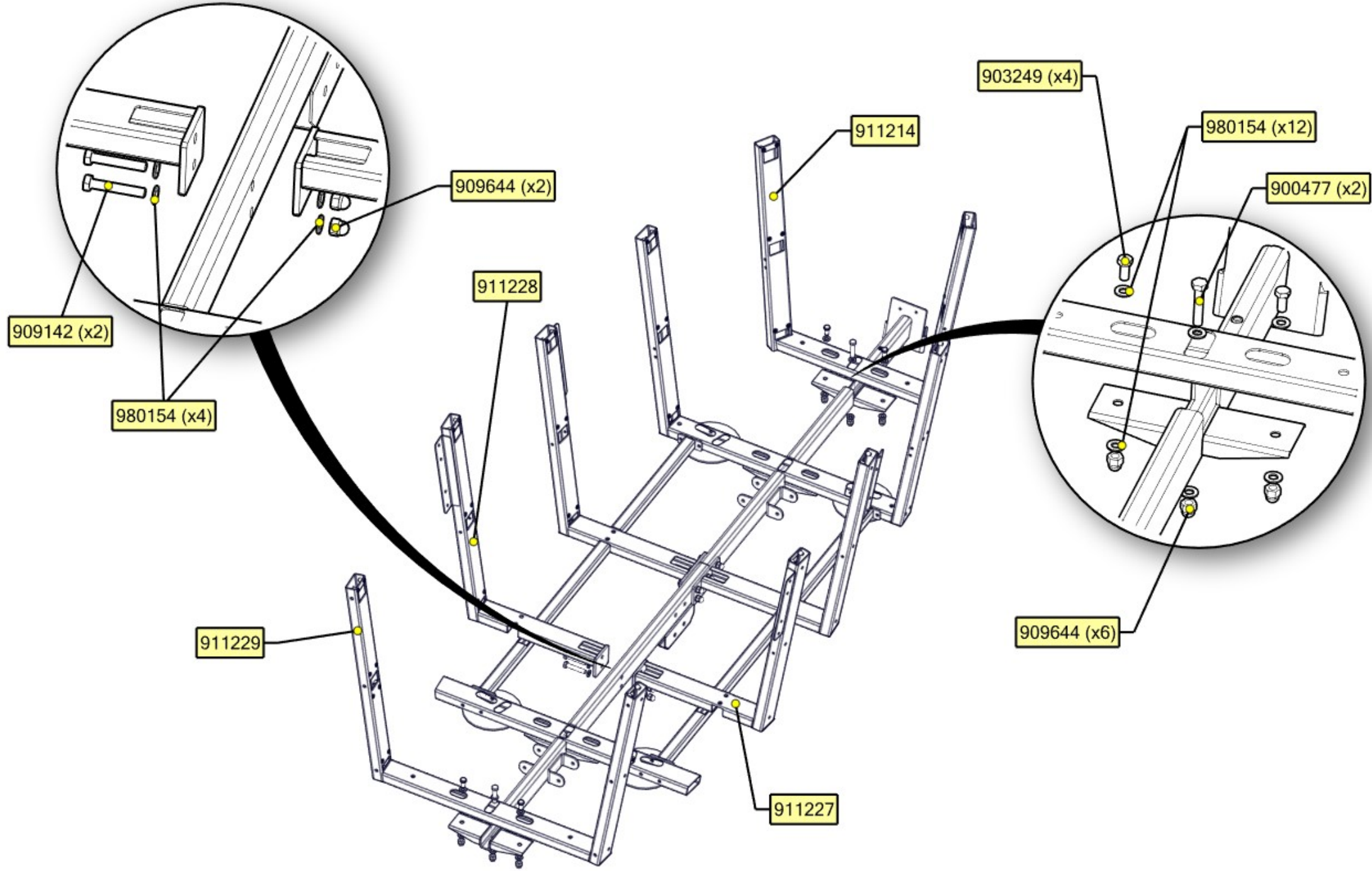

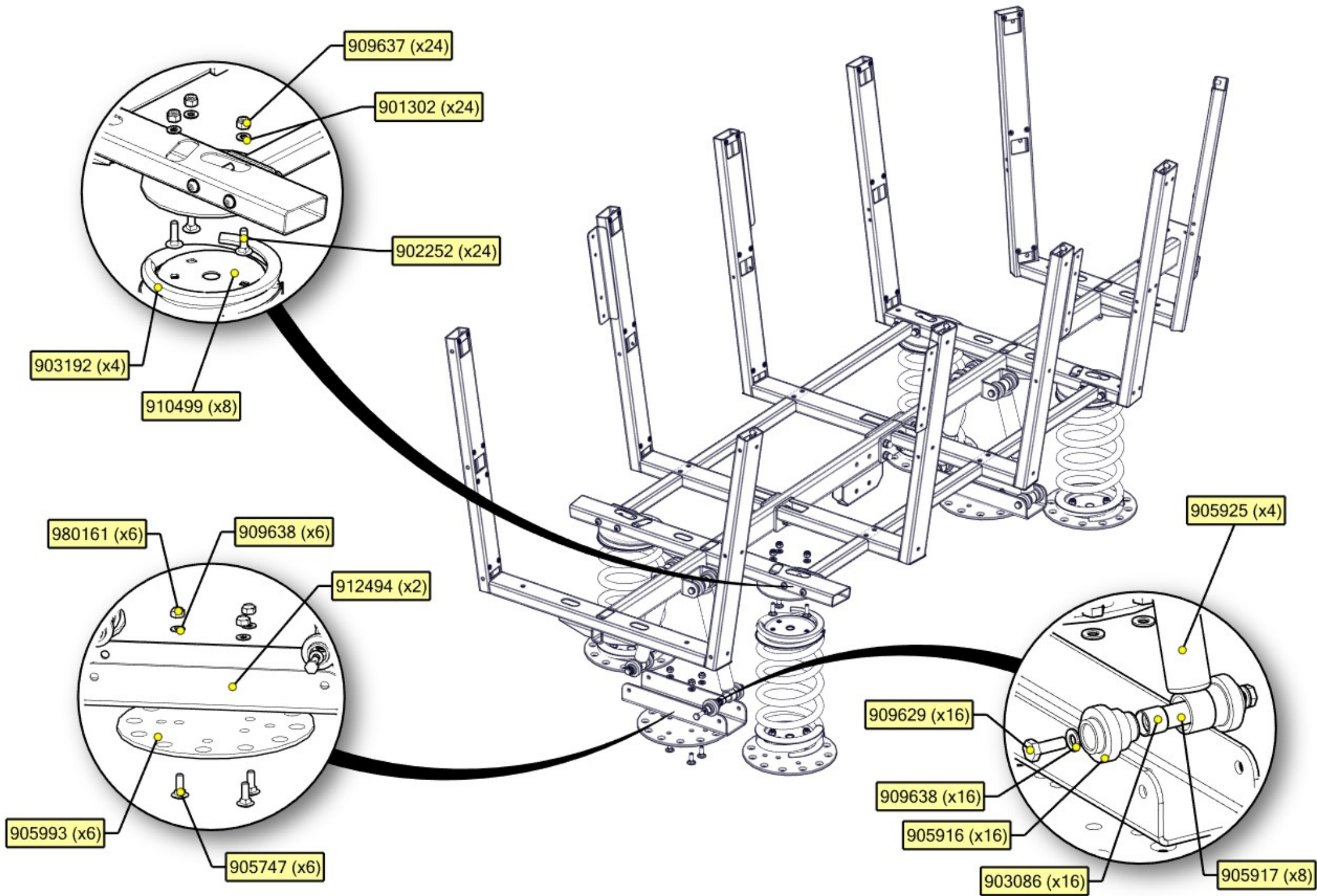



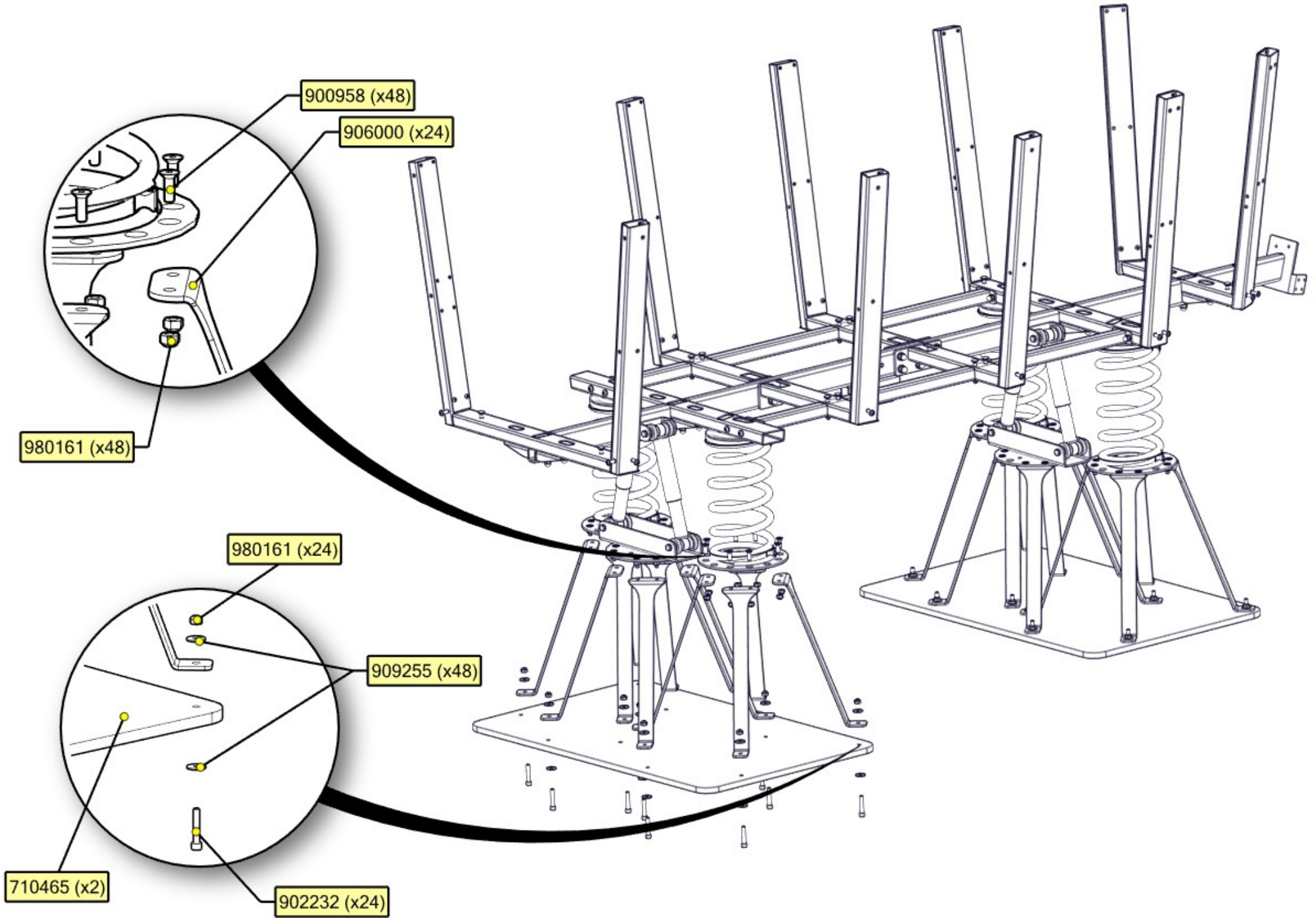

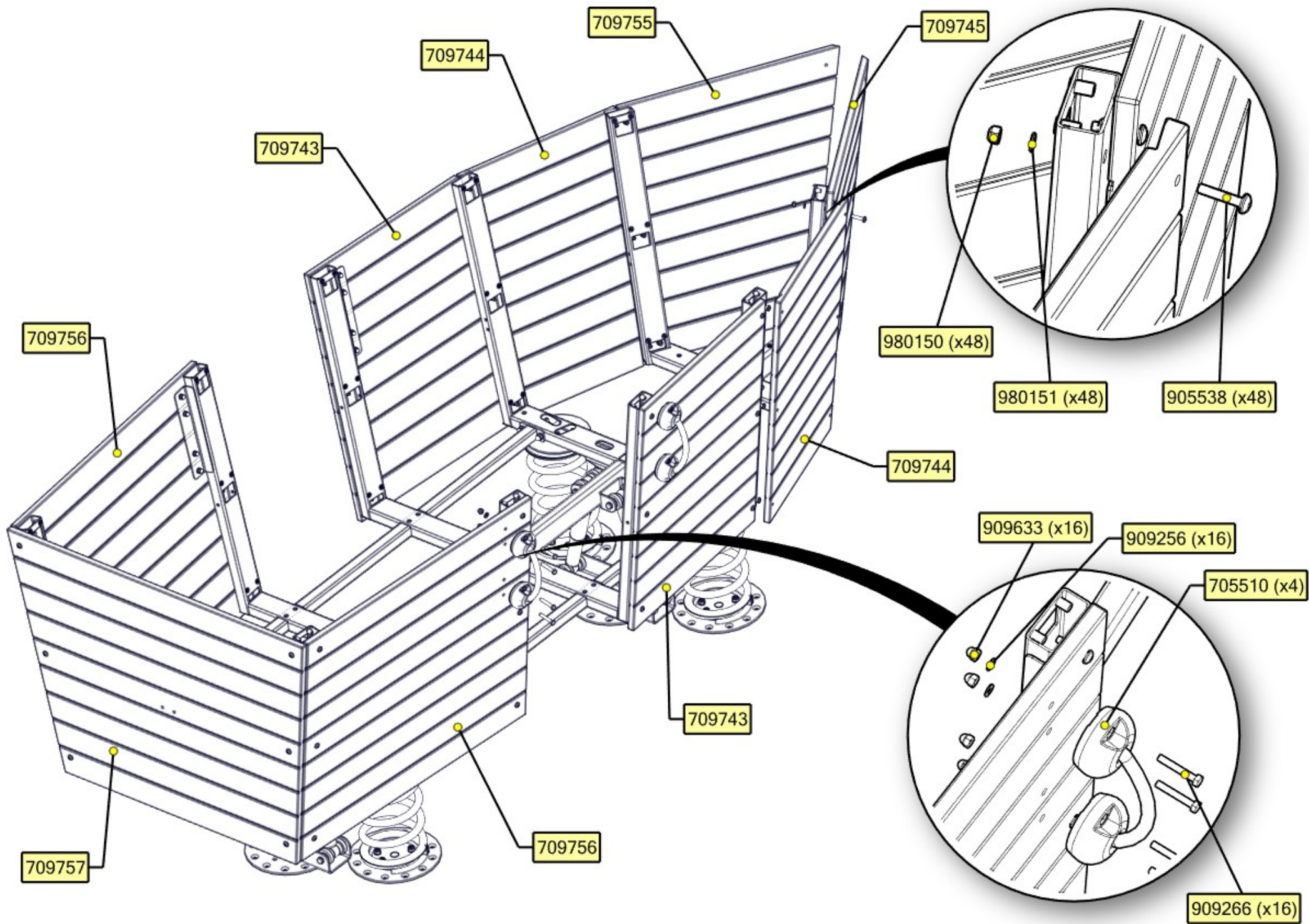

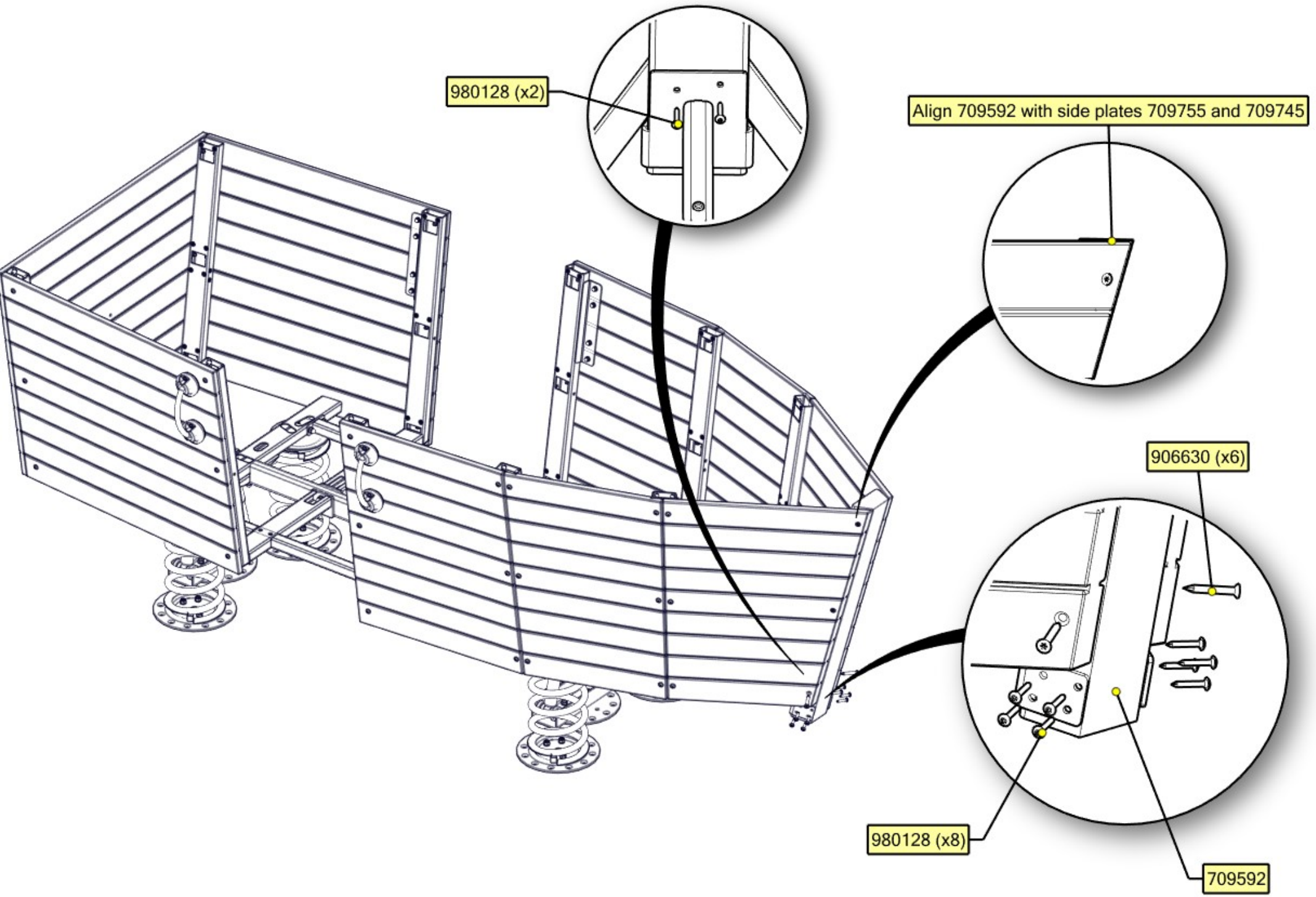

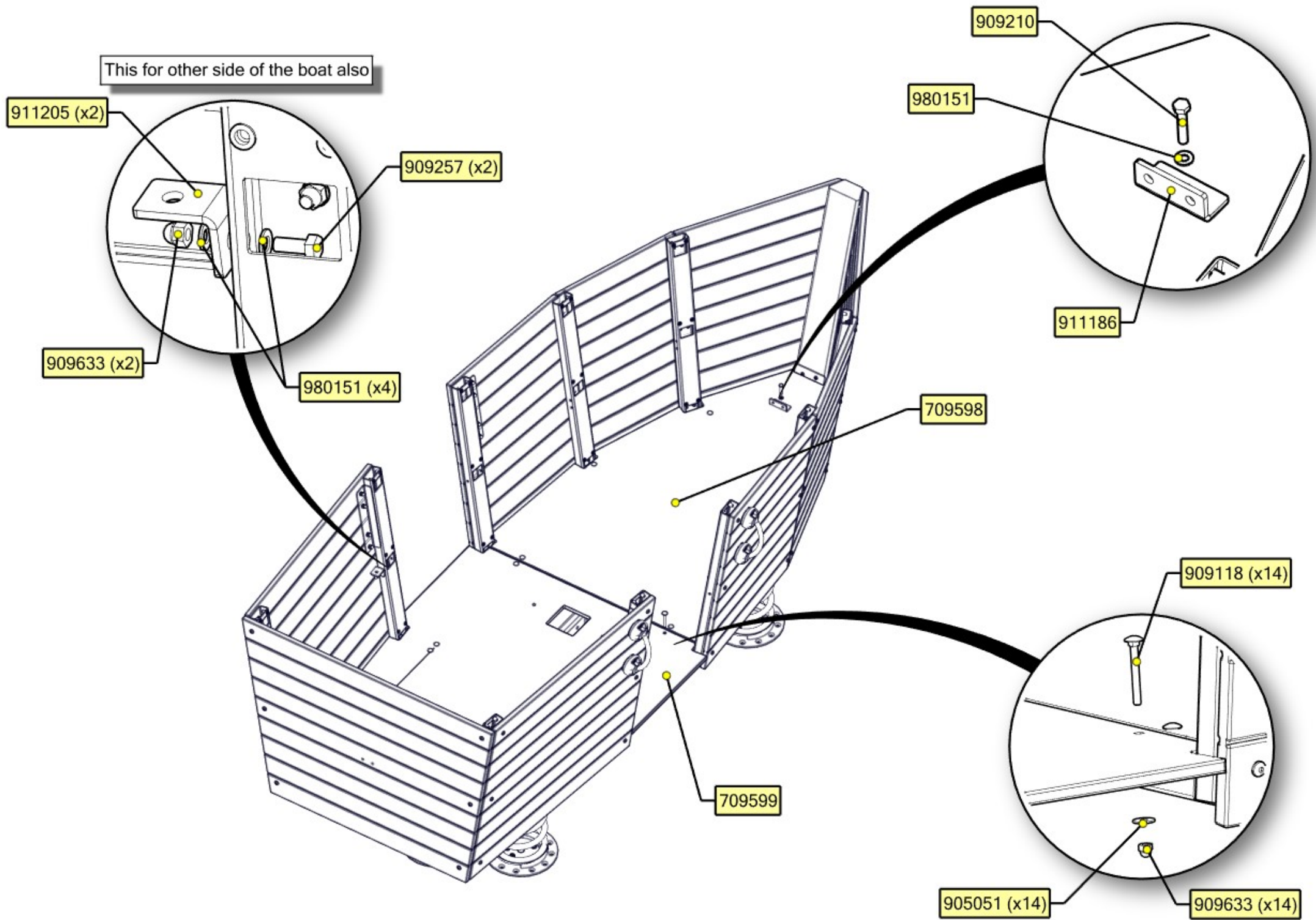

909989 (x10)

905827 (x60)

911196 (x8)

911197 (x2)

911362

905538 (x2)

980151 (x4)

909633 (x2)

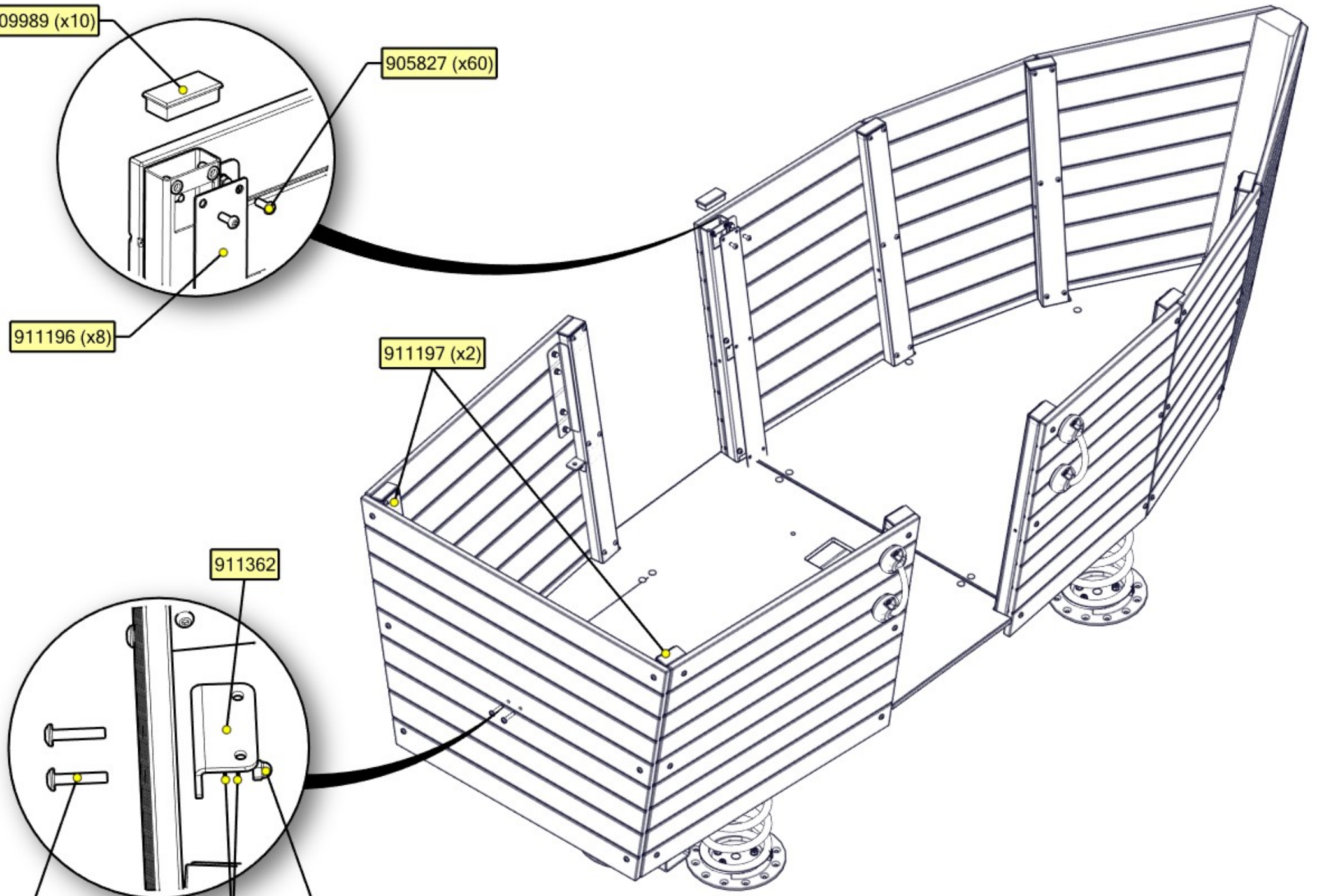

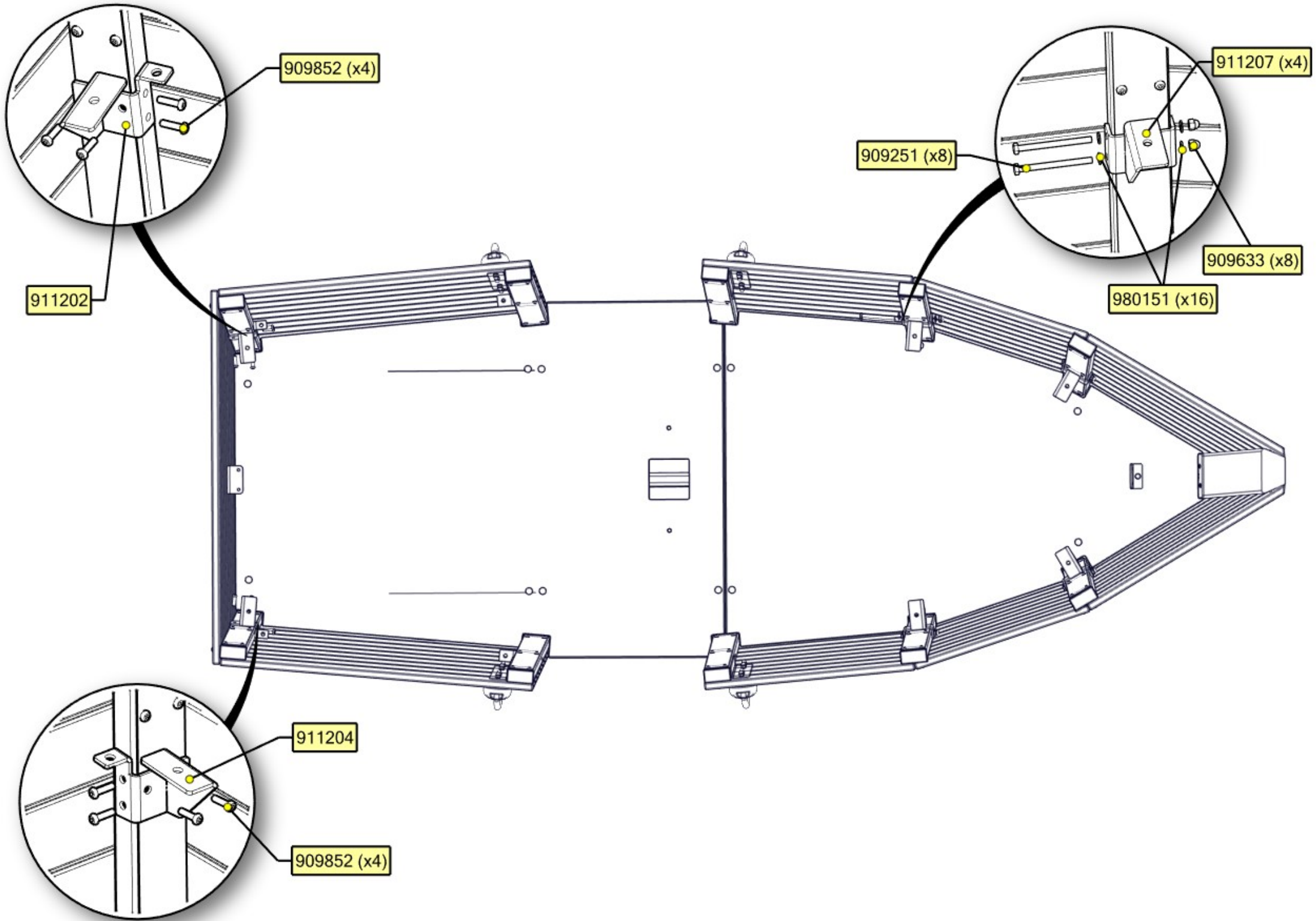

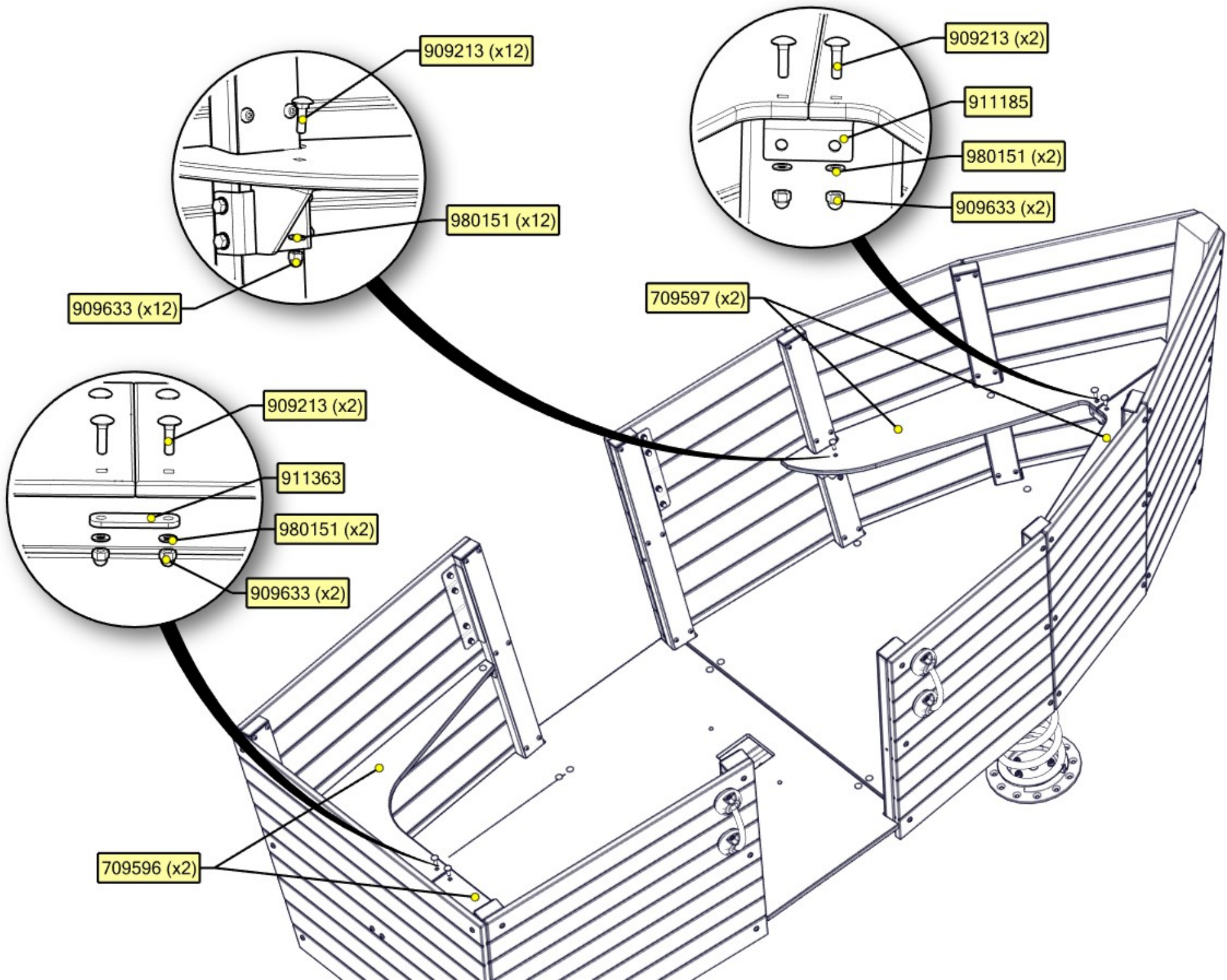

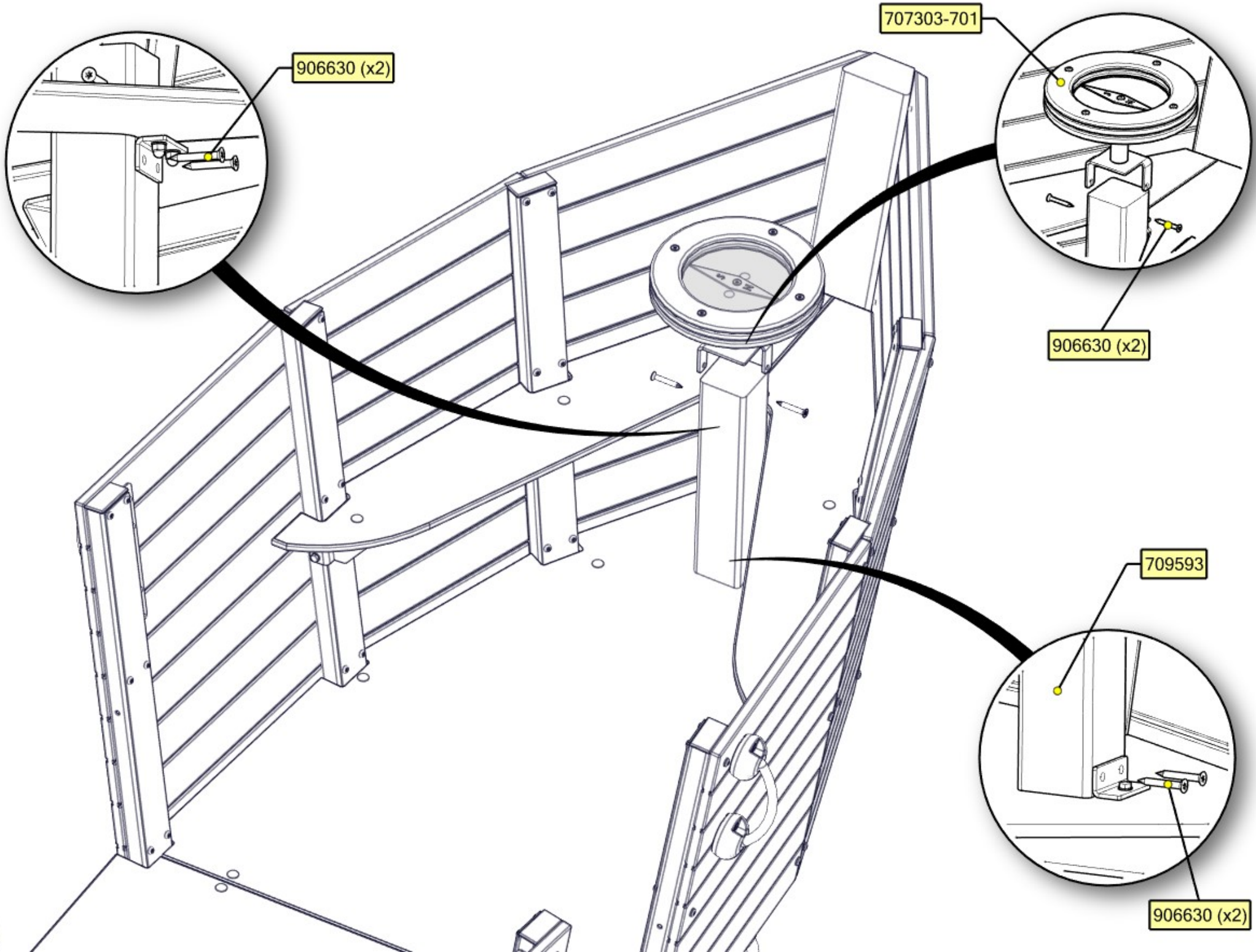



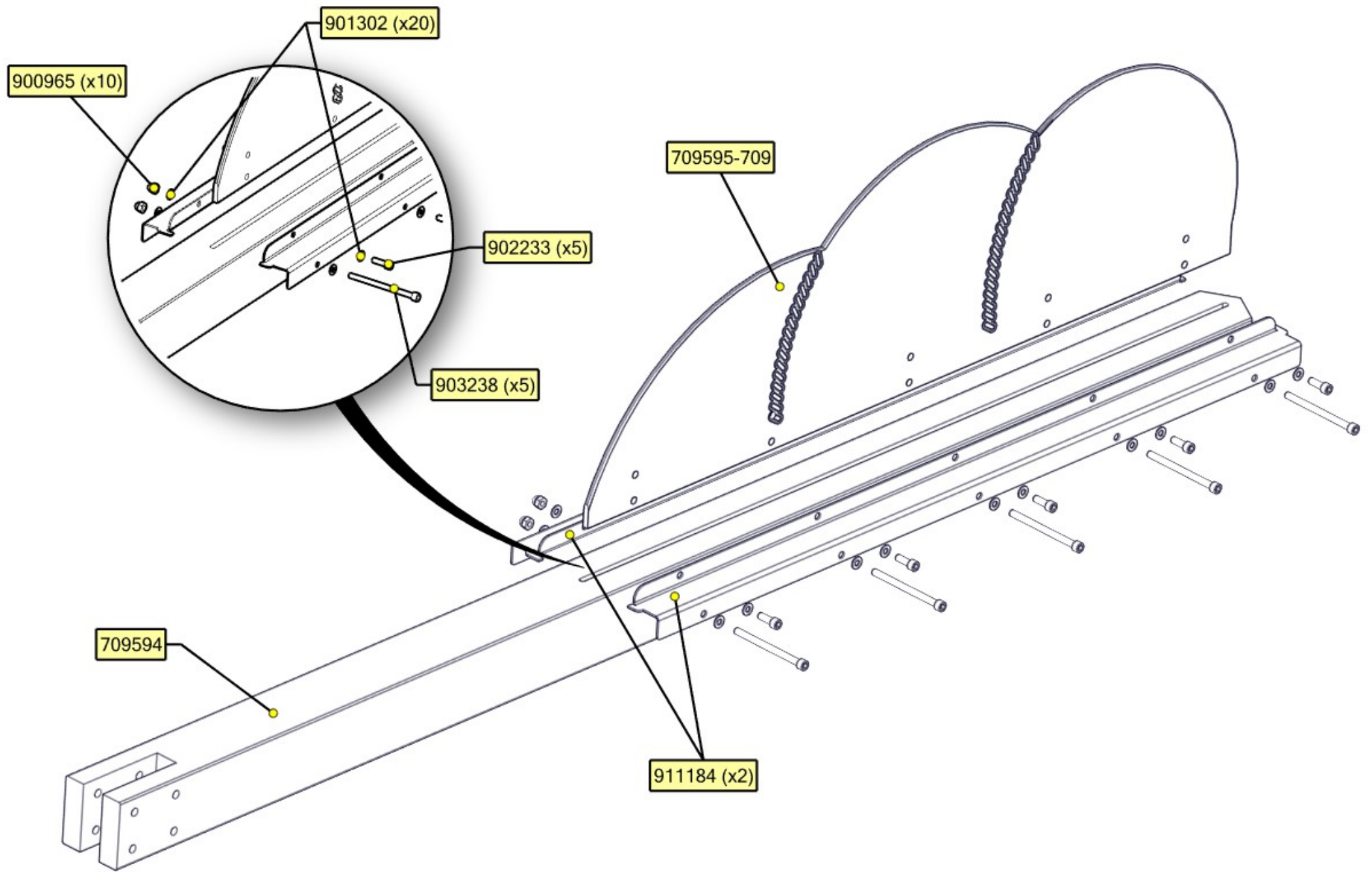

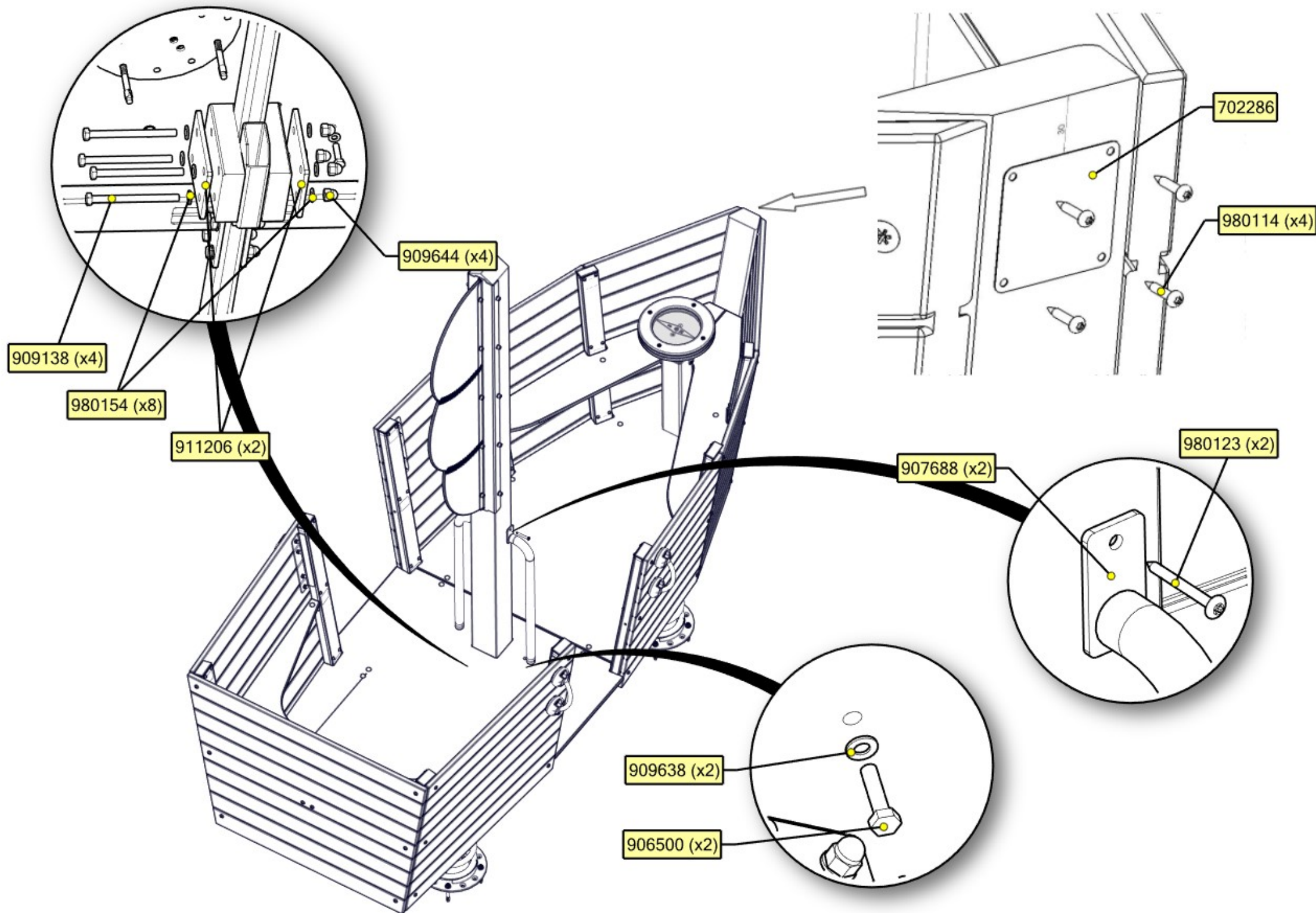

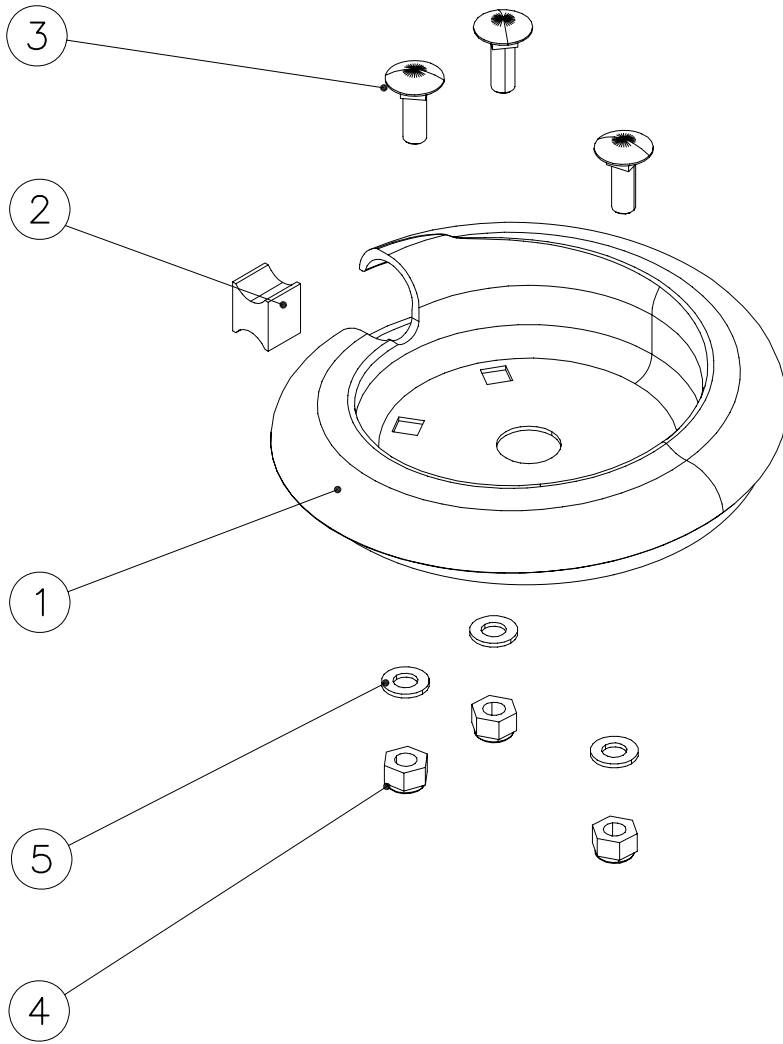

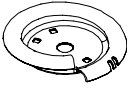
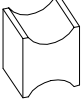
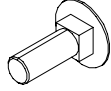

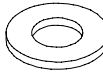
①	PCS 1	②	PCS 1
			
		19x21x25	
③	PCS 3	④	PCS 3
			
M10x35		M10	
⑤	PCS 3		PCS
			
Ø20/10.5			
	PCS		PCS
	PCS		PCS
	PCS		PCS
	PCS		PCS

## Jousen ja kiinnityslevyn kiinnittäminen

### Fixing the spring and gable plate

Aseta jousen kiinnityslevy jousen kierteiden väliin.  
Place the spring berch between the bottom coils



Kierrä kiinnityslevyä kohti kiinnitysalustaa.  
Turn the spring berch towards the anchor



Aseta muovipala kiinnityslevyn kierteen aloitus- ja lopetus osan väliin kuvan osoittamalla tavalla.

Place the plastic piece between coils as shown below



Kierrä kiinnitys levyä myötäpäivää, kunnes muovipala koskettaa jousen kierrettä.

Turn the spring berch clockwise until the plastic piece is in contact to coils below and underneath.

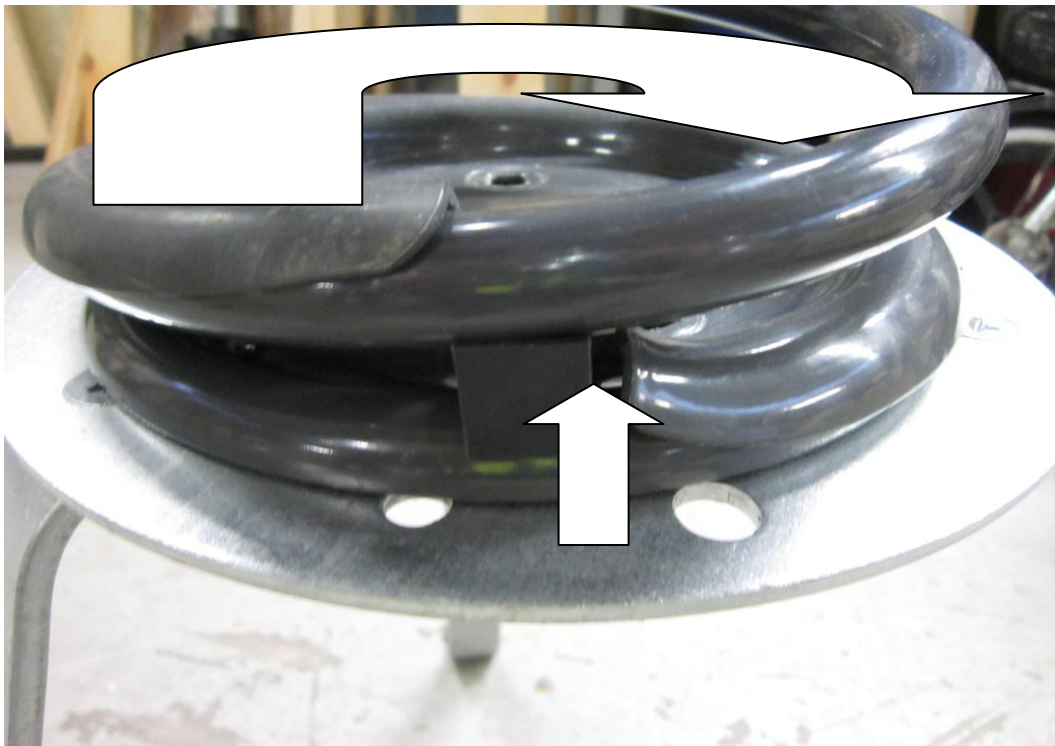

Kohdista kiinnityslevyn pulttien reiät ja perustuksen kiinnitysreiät kohdalleen. 5mm – 10mm rako ennen kiristystä.

Center the fixing holes of anchor and spring berch. There should be 5-10 mm gap between the parts prior to tightening.

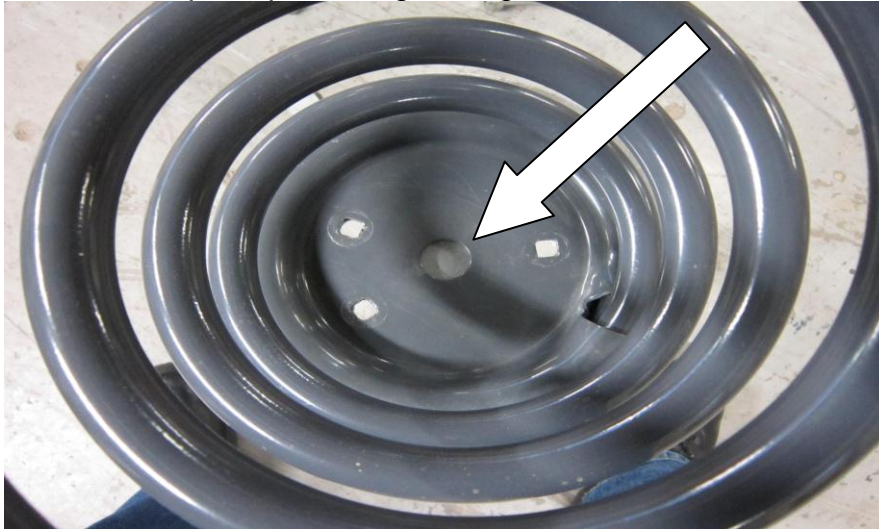

Kiristä huolellisesti pultit vuorotellen kiristäen. Kiristuksen jälkeen osien välillä saa olla korkeintaan 1mm rako keskireiästä katsoen.

Tighten the bolts gradually, about 1 turn at the time. After the tightening, there must not be more than 1mm gap between the parts

